

WIRELESS & MOBILE COMMUNICATION (EE-531)

Max Marks: 70

Date: 26-11-2005

Total Time Allowed: 3 Hours

Instructions:

- Attempt Five Questions in total.
- All Questions Carry equal Marks.
- Erlang tables have been provided with this question paper.

Q.1. (a) Assume a radio receiver is located 10Km from a 50 Watt transmitter. The carrier frequency is 900MHz, free space propagation is assumed, $G_t = 1$, and $G_r = 2$, Calculate:
(i) The power at the receiver, (ii) The magnitude of the Electric Field at the receiver antenna,
(iii) The RMS voltage applied to the receiver input assuming that the receiver antenna has a purely real impedance of 50Ω and is matched to the receiver. (6)

Q.1. (b) How a call initiated by a mobile phone is established? Explain with the help of a timing diagram. (4)

Q.1. (c) Name the main elements of the GSM system architecture and describe their functions. What are the advantages of external radio interface and all internal interfaces of the GSM system? (4)

OR

Q.1. (e) Give reasons for a handoff in GSM and the problems associated with it. What are the typical steps for handoff, what types of handoff can occur? (4)

Q.2. (a) A hexagonal cell within a four-cell system has a radius of 1.519Km. A total of 56 channels are used within the entire system. If the load per user is 0.029 Erlang, and $\lambda = 1$ call per hour, compute the following for an Erlang C system that has a 5% probability of a delayed call:

- How many users per square kilometer will this system support?
- What is the probability that a delayed call will have to wait for more than 10 seconds?
- What is the probability that a call will be delayed for more than 10 seconds? (7)

Q.2. (b) The area of Karachi City is 923 square kilometers and it is covered by a cellular system using a seven-cell re-use pattern. Each cell has a radius of 4 kilometers and the city is allocated 40 MHz of spectrum with a full duplex channel bandwidth of 60KHz. Assume a GOS of 2% for an Erlang B system is specified. If the offered is 0.03 Erlangs, compute:
(i) The number of cells in the service area, (ii) The number of channels per cell,
(iii) Traffic intensity of each cell (iv) The total number of users that can be served for 2% Grade of Service. (7)

OR

Q.2. (b) An area of Karachi has a population of two million resident. Three competing trunked mobile networks (Systems A, B, and C) provide cellular service in this area. System A has 394 cells with 19 channels each, System B has 98 cells with 57 channels each, and System C has 49 cells with 100 channels. Determine the number of users that can be

supported at 2% blocking if each user averages two calls per hour at an average call duration of three minutes. Assuming that all three trunked systems are operated at maximum capacity, compute the percentage market penetration of each cellular provider. (7)

Q.3. (a) An earth station receiving antenna for an INTELSAT VII tracking beacon delivers -119dBm carrier power at the antenna's output flange. The antenna noise temperature is 68K . Following the antenna is a waveguide with 1dB of loss and a physical temperature of 295K . The output of the waveguide is connected to a GaAsFET amplifier with a standard noise figure of 4dB and gain of 25dB . Following the amplifier is a mixer of standard noise figure of 12dB . Calculate the following:

- (i) The GaAsFET amplifier noise temperature
 - (ii) The mixer noise temperature
 - (iii) The waveguide effective input noise temperature
 - (iv) The overall noise temperature of the receiver, referred to the antenna output port
 - (v) The overall noise temperature of the receiver, referred to the GaAsFET input port
- (14)

Q.4. (a) Calculate the orbital period of a LEO Satellite given the following information:
 Earth's Radius = $3444\text{nm} = 6378\text{km}$; Orbit altitude = 1150km ;
 Gravitational co-efficient = $(1.4 \times 10^{16}) \text{ft}^3/\text{sec}^2$ (4)

Q.4. (b) A receiver operating at 2800MHz is shown in the following diagram. Calculate its G/T in dBK^{-1} referred to the output port of the antenna. (6)

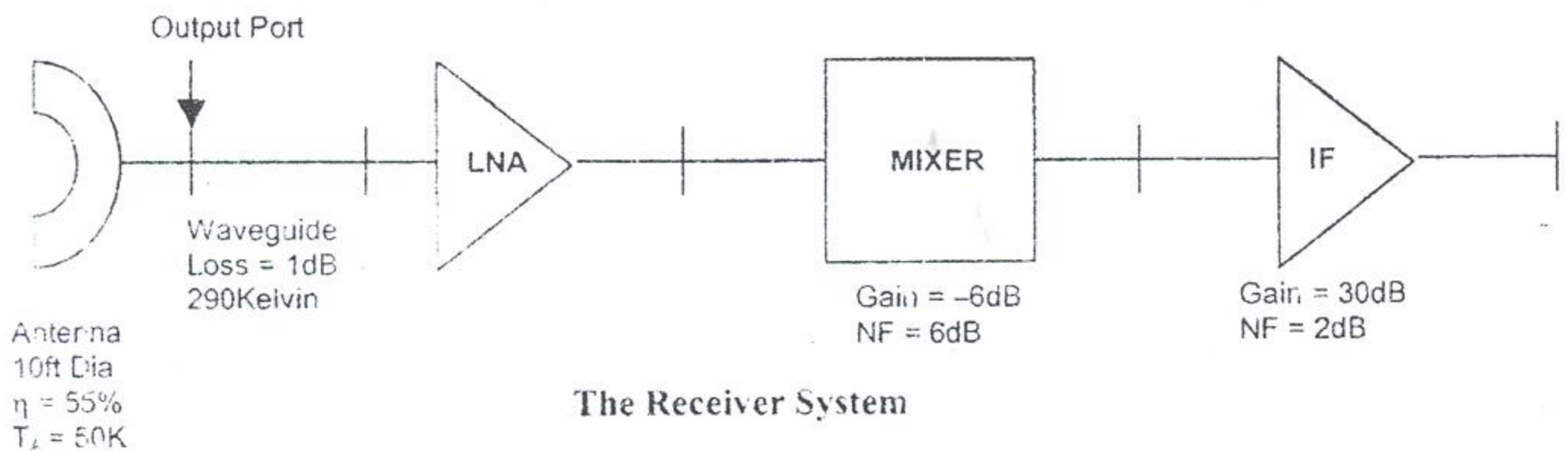

Q.4. (c) What are the primary causes of atmospheric attenuation for satellite communication? (4)
OR

Q.4. (c) What are three factors that limit the number of subchannels that can be provided within a satellite channel via FDMA? (4)

Q.5. (a) List and briefly define the capabilities provided by mobile IP. (4)
OR

Q.5. (a) List and briefly define key requirements for wireless LANs. (4)

Q.5. (b) Consider a 6 Kilometer long WLL link at 28GHz . What is the free space loss? What is the additional loss due to atmospheric absorption on a hot, muggy day with a temperature of 30° and a relative humidity of 100% ? (5)

Q.5. (c) State and explain the factors which can degrade the accuracy and efficiency of a GPS Satellite system. What is a differential GPS? and how it is related to a normal GPS. (5)

(Note: Erlang Tables have been provided with this question paper for candidates)

Wish You All the Best!