

WIRELESS & MOBILE COMMUNICATION - (EE-531)

Dated: 17-05-2007

Max Marks: 70

Time: 3 Hours

**Instructions:**

- Attempt All Questions.
- All Questions Carry equal Marks.
- Erlang tables have been provided with this question paper.

Q.1. (a) Which types of different services does **GSM** offer? Name some examples and give reasons why these services have been separated. (4)

Q.1. (b) Describe the functions of the **MS** and **SIM**. Why does **GSM** separate the **MS** and **SIM**? How and where is user-related data represented/stored in the **GSM** system? How is user data protected from unauthorized access, especially over the air interface? How could the position of an **MS** (not only the current **BTS**) be localized? Think of the **MS** reports regarding signal quality. (5)

Q.1. (c) Name the main elements of the **GSM** system architecture and describe their functions. What are the advantages of external radio interface and all internal interfaces of the **GSM** system? (5)

**OR**

Q.1. (c) What are the functions of authentication and encryption in **GSM**? How is system security maintained? (5)

Q.2. (a) An Urban area has a population of **1.5 million** residents. Consider a  $N=7$  system with a  $Pr[\text{Blocking}] = 1\%$  and average call length of **3 minutes**, find the traffic capacity loss due to trunking for **55 channels** when going from omni directional antennas to  $60^\circ$  sectored antennas. Assume that blocked calls are cleared and the average per user call rate is  $\lambda = 1$  call per hour. Repeat for cluster size  $N=12$ . (5)

Q.2. (b) A hexagonal cell within a four-cell system has a radius of **1.642Km**. A total of **65 channels** are used within the entire system. If the load per user is **0.025 Erlang**, and  $\lambda = 1$  call per hour, compute the following for an **Erlang C** system that has a **5%** probability of a delayed call:

- How many users per square kilometer will this system support?
- What is the probability that a delayed call will have to wait for more than **10 seconds**?
- What is the probability that a call will be delayed for more than **10 seconds**? (5)

Q.2. (c) What are the limitations of a Hexagonal cell in terms of diameter and capacity for the traditional mobile communication? How can the capacity be increased? (4)

Q.3. (a) How a call initiated by a mobile unit is established? Explain with the help of a timing diagram. (4)

Q.3. (b) What are the main problems of signal propagation? Why do radio waves not always follow a straight line? Why is reflection both useful and harmful? (3)

Q.3. (c) What limits the number of simultaneous users in a **TDM/FDM** system compared to a **CDM** system? What happens to the transmission quality of connections if the load gets higher in a cell, i.e., how does an additional user influence the other users in the cell? (3)

**Q.3. (d)** Give reasons for a handover/handoff in **GSM/AMPS** systems and the problems associated with it. Which are the typical steps for handover, what types of handover can occur? (4)

**OR**

**Q.3. (d)** Differentiate between **QOS** and **GOS**. Also compare **Erlang B** based trunked system with **Erlang C** based trunked system. (4)

**Q.4. (a)** A satellite carrying an **11.5GHz** continuous wave beacon transmitter located in geosynchronous orbit **36,786km** from an earth station. The beacon's output power is **200milli-Watt**, and it feeds an antenna with an **18.9dB** gain toward the earth station. The earth station receiving antenna is **4meter** in diameter and has an aperture efficiency of **52%**. The overall system noise temperature of this earth station is **1250Kelvin**. Determine the following:

- (i) The satellite **EIRP** in Watt
- (ii) Receiving Antenna gain in **decibel**
- (iii) Path loss in **decibel**
- (iv) Received Signal Power in **dBm**
- (iv) The earth station **G/T** in **dBk<sup>-1</sup>**
- (v) The Receiver carrier to noise ratio in decibel in a **100Hz** noise bandwidth. (8)

**Q.4. (b)** A receiver operating at **2.8GHz** is shown in the following diagram. Calculate its **G/T** in **dBk<sup>-1</sup>** referred to the output port of the antenna. (6)

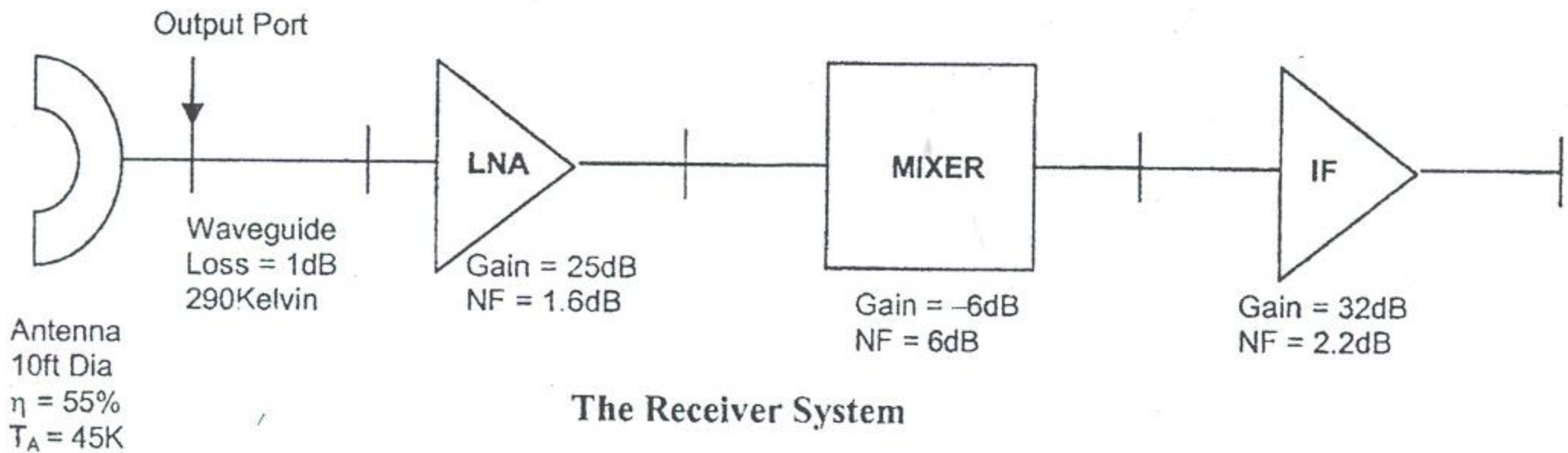

**Q.5. (a)** Consider a **5 Kilometer** long Wireless Local Loop link at **30GHz**. What is the free space loss? What is the additional loss due to atmospheric absorption on a hot, muggy day with a temperature of **32°** and a relative humidity of **100%**? (4)

**Q.5. (b)** Compare and contrast WLL configuration and propagation with conventional local loop using copper media. Also discuss significance of Fresnel Zone. (5)

**Q.5. (c)** Briefly discuss multiple cell **WLAN** configuration and state its key requirements. (5)

**OR**

**Q.5. (c)** Compare and contrast various techniques used for Infrared LANs and Narrowband Microwave LANs. (5)

(Note: Erlang Tables have been provided with this question paper for candidates)

### Erlang B Traffic Table

Maximum Offered Load Versus B and N

N/B	B is in %											
	0.01	0.05	0.1	0.5	1.0	2	5	10	15	20	30	40
1	.0001	.0005	.0010	.0050	.0101	.0204	.0526	.1111	.1765	.2500	.4286	.6667
2	.0142	.0321	.0458	.1054	.1526	.2235	.3813	.5954	.7962	1.000	1.449	2.000
3	.0868	.1517	.1938	.3490	.4555	.6022	.8994	1.271	1.603	1.930	2.633	3.480
4	.2347	.3624	.4393	.7012	.8694	1.092	1.525	2.045	2.501	2.945	3.891	5.021
5	.4520	.6486	.7621	1.132	1.361	1.657	2.219	2.881	3.454	4.010	5.189	6.596
6	.7282	.9957	1.146	1.622	1.909	2.276	2.960	3.758	4.445	5.109	6.514	8.191
7	1.054	1.392	1.579	2.158	2.501	2.935	3.738	4.666	5.461	6.230	7.856	9.800
8	1.422	1.830	2.051	2.730	3.128	3.627	4.543	5.597	6.498	7.369	9.213	11.42
9	1.826	2.302	2.558	3.333	3.783	4.345	5.370	6.546	7.551	8.522	10.58	13.05
10	2.260	2.803	3.092	3.961	4.461	5.084	6.216	7.511	8.616	9.685	11.95	14.68
11	2.722	3.329	3.651	4.610	5.160	5.842	7.076	8.487	9.691	10.86	13.33	16.31
12	3.207	3.878	4.231	5.279	5.876	6.615	7.950	9.474	10.78	12.04	14.72	17.95
13	3.713	4.447	4.831	5.964	6.607	7.402	8.835	10.47	11.87	13.22	16.11	19.60
14	4.239	5.032	5.446	6.663	7.352	8.200	9.730	11.47	12.97	14.41	17.50	21.24
15	4.781	5.634	6.077	7.376	8.108	9.010	10.63	12.48	14.07	15.61	18.90	22.89
16	5.339	6.250	6.722	8.100	8.875	9.828	11.54	13.50	15.18	16.81	20.30	24.54
17	5.911	6.878	7.378	8.834	9.652	10.66	12.46	14.52	16.29	18.01	21.70	26.19
18	6.496	7.519	8.046	9.578	10.44	11.49	13.39	15.55	17.41	19.22	23.10	27.84
19	7.093	8.170	8.724	10.33	11.23	12.33	14.32	16.58	18.53	20.42	24.51	29.50
20	7.701	8.831	9.412	11.09	12.03	13.18	15.25	17.61	19.65	21.64	25.92	31.15
21	8.319	9.501	10.11	11.86	12.84	14.04	16.19	18.65	20.77	22.85	27.33	32.81
22	8.946	10.18	10.81	12.64	13.65	14.90	17.13	19.69	21.90	24.06	28.74	34.46
23	9.583	10.87	11.52	13.42	14.47	15.76	18.08	20.74	23.03	25.28	30.15	36.12
24	10.23	11.56	12.24	14.20	15.30	16.63	19.03	21.78	24.16	26.50	31.56	37.78
25	10.88	12.26	12.97	15.00	16.13	17.51	19.99	22.83	25.30	27.72	32.97	39.44
26	11.54	12.97	13.70	15.80	16.96	18.38	20.94	23.89	26.43	28.94	34.39	41.10
27	12.21	13.69	14.44	16.60	17.80	19.27	21.90	24.94	27.57	30.16	35.80	42.76
28	12.88	14.41	15.18	17.41	18.64	20.15	22.87	26.00	28.71	31.39	37.21	44.41
29	13.56	15.13	15.93	18.22	19.49	21.04	23.83	27.05	29.85	32.61	38.63	46.07
30	14.25	15.86	16.68	19.03	20.34	21.93	24.80	28.11	31.00	33.84	40.05	47.74
31	14.94	16.60	17.44	19.85	21.19	22.83	25.77	29.17	32.14	35.07	41.46	49.40
32	15.63	17.34	18.21	20.68	22.05	23.73	26.75	30.24	33.28	36.30	42.88	51.06
33	16.34	18.09	18.97	21.51	22.91	24.63	27.72	31.30	34.43	37.52	44.30	52.72
34	17.04	18.84	19.74	22.34	23.77	25.53	28.70	32.37	35.58	38.75	45.72	54.38
35	17.75	19.59	20.52	23.17	24.64	26.44	29.68	33.43	36.72	39.99	47.14	56.04
36	18.47	20.35	21.30	24.01	25.51	27.34	30.66	34.50	37.87	41.22	48.56	57.70
37	19.19	21.11	22.08	24.85	26.38	28.25	31.64	35.57	39.02	42.45	49.98	59.37
38	19.91	21.87	22.86	25.69	27.25	29.17	32.62	36.64	40.17	43.68	51.40	61.03
39	20.64	22.64	23.65	26.53	28.13	30.08	33.61	37.72	41.32	44.91	52.82	62.69
40	21.37	23.41	24.44	27.38	29.01	31.00	34.60	38.79	42.48	46.15	54.24	64.35
41	22.11	24.19	25.24	28.23	29.89	31.92	35.58	39.86	43.63	47.38	55.66	66.02
42	22.85	24.97	26.04	29.09	30.77	32.84	36.57	40.94	44.78	48.62	57.08	67.68
43	23.59	25.75	26.84	29.94	31.66	33.76	37.57	42.01	45.94	49.85	58.50	69.34

44	24.33	26.53	27.64	30.80	32.54	34.68	38.56	43.09	47.09	51.09	59.92	71.01
45	25.08	27.32	28.45	31.66	33.43	35.61	39.55	44.17	48.25	52.32	61.35	72.67
46	25.83	28.11	29.26	32.52	34.32	36.53	40.55	45.24	49.40	53.56	62.77	74.33
47	26.59	28.90	30.07	33.38	35.22	37.46	41.54	46.32	50.56	54.80	64.19	76.00
48	27.34	29.70	30.88	34.25	36.11	38.39	42.54	47.40	51.71	56.03	65.61	77.66
49	28.10	30.49	31.69	35.11	37.00	39.32	43.53	48.48	52.87	57.27	67.04	79.32
50	28.87	31.29	32.51	35.98	37.90	40.26	44.53	49.56	54.03	58.51	68.46	80.99
51	29.63	32.09	33.33	36.85	38.80	41.19	45.53	50.64	55.19	59.75	69.88	82.65
52	30.40	32.90	34.15	37.72	39.70	42.12	46.53	51.73	56.35	60.99	71.31	84.32
53	31.17	33.70	34.98	38.60	40.60	43.06	47.53	52.81	57.50	62.22	72.73	85.98
54	31.94	34.51	35.80	39.47	41.51	44.00	48.54	53.89	58.66	63.46	74.15	87.65
55	32.72	35.32	36.63	40.35	42.41	44.94	49.54	54.98	59.82	64.70	75.58	89.31
56	33.49	36.13	37.46	41.23	43.32	45.88	50.54	56.06	60.98	65.94	77.00	90.97
57	34.27	36.95	38.29	42.11	44.22	46.82	51.55	57.14	62.14	67.18	78.43	92.64
58	35.05	37.76	39.12	42.99	45.13	47.76	52.55	58.23	63.31	68.42	79.85	94.30
59	35.84	38.58	39.96	43.87	46.04	48.70	53.56	59.32	64.47	69.66	81.27	95.97
60	36.62	39.40	40.80	44.76	46.95	49.64	54.57	60.40	65.63	70.90	82.70	97.63
61	37.41	40.22	41.63	45.64	47.86	50.59	55.57	61.49	66.79	72.14	84.12	99.30
62	38.20	41.05	42.47	46.53	48.77	51.53	56.58	62.58	67.95	73.38	85.55	101.0
63	38.99	41.87	43.31	47.42	49.69	52.48	57.59	63.66	69.11	74.63	86.97	102.6
64	39.78	42.70	44.16	48.31	50.60	53.43	58.60	64.75	70.28	75.87	88.40	104.3
65	40.58	43.52	45.00	49.20	51.52	54.38	59.61	65.84	71.44	77.11	89.82	106.0
66	41.38	44.35	45.85	50.09	52.44	55.33	60.62	66.93	72.60	78.35	91.25	107.6
67	42.17	45.18	46.69	50.98	53.35	56.28	61.63	68.02	73.77	79.59	92.67	109.3
68	42.97	46.02	47.54	51.87	54.27	57.23	62.64	69.11	74.93	80.83	94.10	111.0
69	43.77	46.85	48.39	52.77	55.19	58.18	63.65	70.20	76.09	82.08	95.52	112.6
70	44.58	47.68	49.24	53.66	56.11	59.13	64.67	71.29	77.26	83.32	96.95	114.3
71	45.38	48.52	50.09	54.56	57.03	60.08	65.68	72.38	78.42	84.56	98.37	116.0
72	46.19	49.36	50.94	55.46	57.96	61.04	66.69	73.47	79.59	85.80	99.80	117.6
73	47.00	50.20	51.80	56.35	58.88	61.99	67.71	74.56	80.75	87.05	101.2	119.3
74	47.81	51.04	52.65	57.25	59.80	62.95	68.72	75.65	81.92	88.29	102.7	120.9
75	48.62	51.88	53.51	58.15	60.73	63.90	69.74	76.74	83.08	89.53	104.1	122.6
76	49.43	52.72	54.37	59.05	61.65	64.86	70.75	77.83	84.25	90.78	105.5	124.3
77	50.24	53.56	55.23	59.96	62.58	65.81	71.77	78.93	85.41	92.02	106.9	125.9
78	51.05	54.41	56.09	60.86	63.51	66.77	72.79	80.02	86.58	93.26	108.4	127.6
79	51.87	55.25	56.95	61.76	64.43	67.73	73.80	81.11	87.74	94.51	109.8	129.3
80	52.69	56.10	57.81	62.67	65.36	68.69	74.82	82.20	88.91	95.75	111.2	130.9
81	53.51	56.95	58.67	63.57	66.29	69.65	75.84	83.30	90.08	96.99	112.6	132.6
82	54.33	57.80	59.54	64.48	67.22	70.61	76.86	84.39	91.24	98.24	114.1	134.3
83	55.15	58.65	60.40	65.39	68.15	71.57	77.87	85.48	92.41	99.48	115.5	135.9
84	55.97	59.50	61.27	66.29	69.08	72.53	78.89	86.58	93.58	100.7	116.9	137.6
85	56.79	60.35	62.14	67.20	70.02	73.49	79.91	87.67	94.74	102.0	118.3	139.3
86	57.62	61.21	63.00	68.11	70.95	74.45	80.93	88.77	95.91	103.2	119.8	140.9
87	58.44	62.06	63.87	69.02	71.88	75.42	81.95	89.86	97.08	104.5	121.2	142.6
88	59.27	62.92	64.74	69.93	72.82	76.38	82.97	90.96	98.25	105.7	122.6	144.3
89	60.10	63.77	65.61	70.84	73.75	77.34	83.99	92.05	99.41	107.0	124.0	145.9
90	60.92	64.63	66.48	71.76	74.68	78.31	85.01	93.15	100.6	108.2	125.5	147.6

91	61.75	65.49	67.36	72.67	75.62	79.27	86.04	94.24	101.8	109.4	126.9	149.3
92	62.58	66.35	68.23	73.58	76.56	80.24	87.06	95.34	102.9	110.7	128.3	150.9
93	63.42	67.21	69.10	74.50	77.49	81.20	88.08	96.43	104.1	111.9	129.8	152.6
94	64.25	68.07	69.98	75.41	78.43	82.17	89.10	97.53	105.3	113.2	131.2	154.3
95	65.08	68.93	70.85	76.33	79.37	83.13	90.12	98.63	106.4	114.4	132.6	155.9
96	65.92	69.79	71.73	77.24	80.31	84.10	91.15	99.72	107.6	115.7	134.0	157.6
97	66.75	70.65	72.61	78.16	81.25	85.07	92.17	100.8	108.8	116.9	135.5	159.3
98	67.59	71.52	73.48	79.07	82.18	86.04	93.19	101.9	109.9	118.2	136.9	160.9
99	68.43	72.38	74.36	79.99	83.12	87.00	94.22	103.0	111.1	119.4	138.3	162.6
100	69.27	73.25	75.24	80.91	84.06	87.97	95.24	104.1	112.3	120.6	139.7	164.3

N is the number of servers. The numerical column headings indicate blocking probability B in %. Table generated by Dan Dexter

### Erlang C Traffic Table

Maximum Offered Load Versus B and N

N/B	B is in %											
	0.01	0.05	0.1	0.5	1.0	2	5	10	15	20	30	40
1	.0001	.0005	.0010	.0050	.0100	.0200	.0500	.1000	.1500	.2000	.3000	.4000
2	.0142	.0319	.0452	.1025	.1465	.2103	.3422	.5000	.6278	.7403	.9390	1.117
3	.0860	.1490	.1894	.3339	.4291	.5545	.7876	1.040	1.231	1.393	1.667	1.903
4	.2310	.3533	.4257	.6641	.8100	.9939	1.319	1.653	1.899	2.102	2.440	2.725
5	.4428	.6289	.7342	1.065	1.259	1.497	1.905	2.313	2.607	2.847	3.241	3.569
6	.7110	.9616	1.099	1.519	1.758	2.047	2.532	3.007	3.344	3.617	4.062	4.428
7	1.026	1.341	1.510	2.014	2.297	2.633	3.188	3.725	4.103	4.406	4.897	5.298
8	1.382	1.758	1.958	2.543	2.866	3.246	3.869	4.463	4.878	5.210	5.744	6.178
9	1.771	2.208	2.436	3.100	3.460	3.883	4.569	5.218	5.668	6.027	6.600	7.065
10	2.189	2.685	2.942	3.679	4.077	4.540	5.285	5.986	6.469	6.853	7.465	7.959
11	2.634	3.186	3.470	4.279	4.712	5.213	6.015	6.765	7.280	7.688	8.336	8.857
12	3.100	3.708	4.018	4.896	5.363	5.901	6.758	7.554	8.099	8.530	9.212	9.761
13	3.587	4.248	4.584	5.529	6.028	6.602	7.511	8.352	8.926	9.379	10.09	10.67
14	4.092	4.805	5.166	6.175	6.705	7.313	8.273	9.158	9.760	10.23	10.98	11.58
15	4.614	5.377	5.762	6.833	7.394	8.035	9.044	9.970	10.60	11.09	11.87	12.49
16	5.150	5.962	6.371	7.502	8.093	8.766	9.822	10.79	11.44	11.96	12.77	13.41
17	5.699	6.560	6.991	8.182	8.801	9.505	10.61	11.61	12.29	12.83	13.66	14.33
18	6.261	7.169	7.622	8.871	9.518	10.25	11.40	12.44	13.15	13.70	14.56	15.25
19	6.835	7.788	8.263	9.568	10.24	11.01	12.20	13.28	14.01	14.58	15.47	16.18
20	7.419	8.417	8.914	10.27	10.97	11.77	13.00	14.12	14.87	15.45	16.37	17.10
21	8.013	9.055	9.572	10.99	11.71	12.53	13.81	14.96	15.73	16.34	17.28	18.03
22	8.616	9.702	10.24	11.70	12.46	13.30	14.62	15.81	16.60	17.22	18.19	18.96
23	9.228	10.36	10.91	12.43	13.21	14.08	15.43	16.65	17.47	18.11	19.10	19.89
24	9.848	11.02	11.59	13.16	13.96	14.86	16.25	17.51	18.35	19.00	20.02	20.82
25	10.48	11.69	12.28	13.90	14.72	15.65	17.08	18.36	19.22	19.89	20.93	21.76
26	11.11	12.36	12.97	14.64	15.49	16.44	17.91	19.22	20.10	20.79	21.85	22.69
27	11.75	13.04	13.67	15.38	16.26	17.23	18.74	20.08	20.98	21.68	22.77	23.63
28	12.40	13.73	14.38	16.14	17.03	18.03	19.57	20.95	21.87	22.58	23.69	24.57
29	13.05	14.42	15.09	16.89	17.81	18.83	20.41	21.82	22.75	23.48	24.61	25.50
30	13.71	15.12	15.80	17.65	18.59	19.64	21.25	22.68	23.64	24.38	25.54	26.44
31	14.38	15.82	16.52	18.42	19.37	20.45	22.09	23.56	24.53	25.29	26.46	27.38
32	15.05	16.53	17.25	19.18	20.16	21.26	22.93	24.43	25.42	26.19	27.39	28.33
33	15.72	17.24	17.97	19.95	20.95	22.07	23.78	25.30	26.32	27.10	28.31	29.27
34	16.40	17.95	18.71	20.73	21.75	22.89	24.63	26.18	27.21	28.01	29.24	30.21
35	17.09	18.67	19.44	21.51	22.55	23.71	25.48	27.06	28.11	28.92	30.17	31.16
36	17.78	19.39	20.18	22.29	23.35	24.53	26.34	27.94	29.00	29.83	31.10	32.10
37	18.47	20.12	20.92	23.07	24.15	25.36	27.19	28.82	29.90	30.74	32.03	33.05
38	19.17	20.85	21.67	23.86	24.96	26.18	28.05	29.71	30.80	31.65	32.97	34.00
39	19.87	21.59	22.42	24.65	25.77	27.01	28.91	30.59	31.71	32.57	33.90	34.94
40	20.58	22.33	23.17	25.44	26.58	27.84	29.77	31.48	32.61	33.48	34.83	35.89
41	21.28	23.07	23.93	26.23	27.39	28.68	30.63	32.37	33.51	34.40	35.77	36.84
42	22.00	23.81	24.69	27.03	28.21	29.51	31.50	33.26	34.42	35.32	36.70	37.79
43	22.71	24.56	25.45	27.83	29.02	30.35	32.36	34.15	35.33	36.23	37.64	38.74

44	23.43	25.31	26.22	28.63	29.84	31.19	33.23	35.04	36.23	37.15	38.58	39.69
45	24.15	26.06	26.98	29.44	30.67	32.03	34.10	35.93	37.14	38.07	39.51	40.64
46	24.88	26.82	27.75	30.24	31.49	32.87	34.97	36.83	38.05	39.00	40.45	41.59
47	25.60	27.57	28.52	31.05	32.32	33.72	35.84	37.72	38.96	39.92	41.39	42.54
48	26.34	28.33	29.30	31.86	33.14	34.56	36.72	38.62	39.87	40.84	42.33	43.50
49	27.07	29.10	30.08	32.68	33.97	35.41	37.59	39.52	40.79	41.76	43.27	44.45
50	27.80	29.86	30.86	33.49	34.80	36.26	38.47	40.42	41.70	42.69	44.21	45.40
51	28.54	30.63	31.64	34.31	35.64	37.11	39.35	41.32	42.61	43.61	45.15	46.36
52	29.28	31.40	32.42	35.12	36.47	37.97	40.23	42.22	43.53	44.54	46.10	47.31
53	30.03	32.17	33.21	35.94	37.31	38.82	41.10	43.12	44.44	45.47	47.04	48.27
54	30.77	32.95	33.99	36.76	38.15	39.67	41.99	44.02	45.36	46.39	47.98	49.22
55	31.52	33.72	34.78	37.59	38.99	40.53	42.87	44.93	46.28	47.32	48.93	50.18
56	32.27	34.50	35.57	38.41	39.83	41.39	43.75	45.83	47.20	48.25	49.87	51.13
57	33.03	35.28	36.37	39.24	40.67	42.25	44.64	46.74	48.12	49.18	50.82	52.09
58	33.78	36.06	37.16	40.07	41.51	43.11	45.52	47.64	49.04	50.11	51.76	53.05
59	34.54	36.85	37.96	40.90	42.36	43.97	46.41	48.55	49.96	51.04	52.71	54.01
60	35.30	37.63	38.76	41.73	43.20	44.83	47.29	49.46	50.88	51.97	53.65	54.96
61	36.06	38.42	39.56	42.56	44.05	45.70	48.18	50.37	51.80	52.90	54.60	55.92
62	36.82	39.21	40.36	43.39	44.90	46.56	49.07	51.27	52.72	53.83	55.55	56.88
63	37.59	40.00	41.16	44.23	45.75	47.43	49.96	52.18	53.64	54.77	56.49	57.84
64	38.35	40.80	41.97	45.06	46.60	48.30	50.85	53.10	54.57	55.70	57.44	58.80
65	39.12	41.59	42.78	45.90	47.45	49.16	51.74	54.01	55.49	56.63	58.39	59.76
66	39.89	42.39	43.58	46.74	48.30	50.03	52.64	54.92	56.42	57.57	59.34	60.72
67	40.66	43.18	44.39	47.58	49.16	50.90	53.53	55.83	57.34	58.50	60.29	61.68
68	41.44	43.98	45.20	48.42	50.01	51.77	54.42	56.75	58.27	59.44	61.24	62.64
69	42.21	44.78	46.02	49.26	50.87	52.65	55.32	57.66	59.20	60.37	62.19	63.60
70	42.99	45.58	46.83	50.10	51.73	53.52	56.21	58.57	60.12	61.31	63.14	64.56
71	43.77	46.39	47.64	50.95	52.59	54.39	57.11	59.49	61.05	62.25	64.09	65.52
72	44.55	47.19	48.46	51.79	53.45	55.27	58.01	60.41	61.98	63.18	65.04	66.48
73	45.33	48.00	49.28	52.64	54.31	56.14	58.90	61.32	62.91	64.12	65.99	67.44
74	46.11	48.81	50.10	53.49	55.17	57.02	59.80	62.24	63.84	65.06	66.94	68.40
75	46.90	49.61	50.92	54.34	56.03	57.90	60.70	63.16	64.76	66.00	67.89	69.37
76	47.68	50.42	51.74	55.19	56.89	58.78	61.60	64.07	65.69	66.94	68.85	70.33
77	48.47	51.23	52.56	56.04	57.76	59.65	62.50	64.99	66.63	67.88	69.80	71.29
78	49.26	52.05	53.38	56.89	58.62	60.53	63.40	65.91	67.56	68.82	70.75	72.25
79	50.05	52.86	54.21	57.74	59.49	61.41	64.30	66.83	68.49	69.76	71.70	73.22
80	50.84	53.68	55.03	58.60	60.36	62.30	65.21	67.75	69.42	70.70	72.66	74.18
81	51.63	54.49	55.86	59.45	61.22	63.18	66.11	68.67	70.35	71.64	73.61	75.14
82	52.43	55.31	56.69	60.30	62.09	64.06	67.01	69.59	71.28	72.58	74.57	76.11
83	53.22	56.13	57.52	61.16	62.96	64.94	67.92	70.52	72.22	73.52	75.52	77.07
84	54.02	56.95	58.35	62.02	63.83	65.83	68.82	71.44	73.15	74.46	76.47	78.04
85	54.81	57.77	59.18	62.88	64.70	66.71	69.73	72.36	74.08	75.40	77.43	79.00
86	55.61	58.59	60.01	63.73	65.57	67.60	70.63	73.28	75.02	76.35	78.38	79.97
87	56.41	59.41	60.84	64.59	66.45	68.48	71.54	74.21	75.95	77.29	79.34	80.93
88	57.21	60.23	61.67	65.45	67.32	69.37	72.45	75.13	76.89	78.23	80.30	81.90
89	58.02	61.06	62.51	66.32	68.19	70.26	73.35	76.06	77.82	79.18	81.25	82.86
90	58.82	61.88	63.34	67.18	69.07	71.15	74.26	76.98	78.76	80.12	82.21	83.83

91	59.62	62.71	64.18	68.04	69.94	72.04	75.17	77.91	79.69	81.06	83.16	84.79
92	60.43	63.54	65.02	68.90	70.82	72.92	76.08	78.83	80.63	82.01	84.12	85.76
93	61.23	64.36	65.86	69.77	71.70	73.81	76.99	79.76	81.57	82.95	85.08	86.73
94	62.04	65.19	66.70	70.63	72.57	74.71	77.90	80.69	82.50	83.90	86.03	87.69
95	62.85	66.02	67.54	71.50	73.45	75.60	78.81	81.61	83.44	84.84	86.99	88.66
96	63.66	66.85	68.38	72.36	74.33	76.49	79.72	82.54	84.38	85.79	87.95	89.62
97	64.47	67.69	69.22	73.23	75.21	77.38	80.63	83.47	85.32	86.74	88.91	90.59
98	65.28	68.52	70.06	74.10	76.09	78.27	81.54	84.39	86.26	87.68	89.87	91.56
99	66.09	69.35	70.90	74.97	76.97	79.17	82.46	85.32	87.20	88.63	90.82	92.53
100	66.91	70.19	71.75	75.84	77.85	80.06	83.37	86.25	88.13	89.58	91.78	93.49

N is the number of servers. The numerical column headings indicate blocking probability B in %. Table generated by Dan Dexter